



MF1117 | 379X366 cm

## ATTREZZO FITNESS PER IL RINFORZO DEI MUSCOLI DELLE BRACCIA

Attrezzo realizzato in acciaio zincato e verniciato con profili da 100x100 mm., tappi copripalo in plastica.

- Dimensioni 79 x 66 x h132 cm.
- Area di sicurezza 379 x 366 cm.
- Età d'uso consigliata: +14 anni
- Peso massimo supportato: 140 kg
- Attrezzatura rispondente alla EN 16630



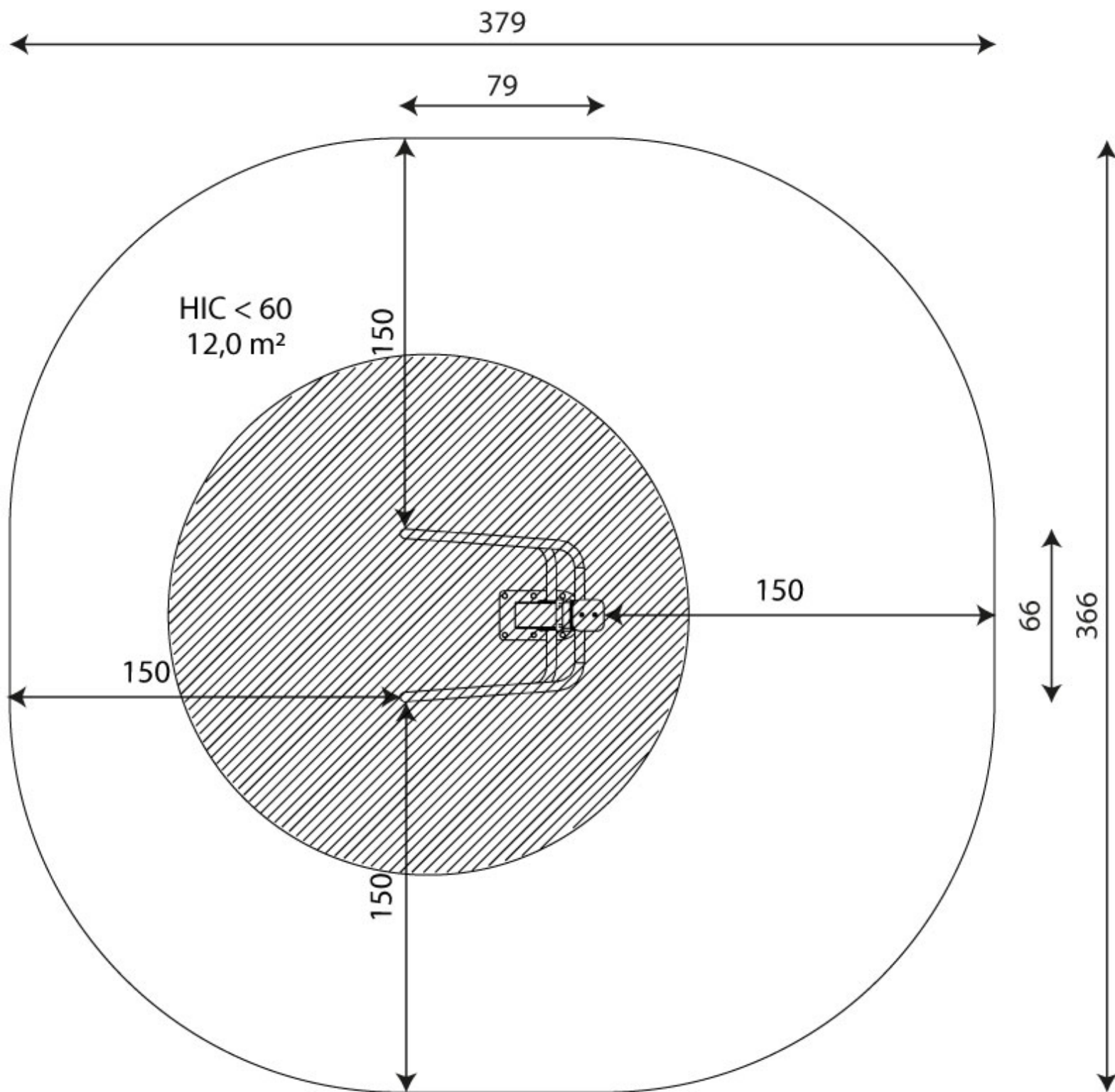

ATTREZZO FITNESS PER IL RINFORZO DEI MUSCOLI DELLE BRACCIA-MF117



P.M. MODIFICHE s.r.l.  
Via Amicizia 15 - 36027 Rosà (VI) - Italy  
CF / P.iva 02326230246

myfun@pmmodifiche.it  
www.myfungiochi.it  
Tel +39 0424 219292

-  codice
-  altezza di caduta
-  area sicurezza
-  misure
-  pavimentazione



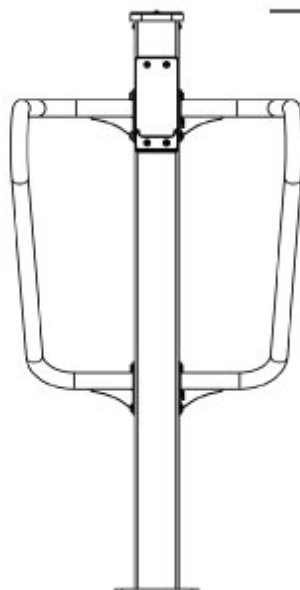

132

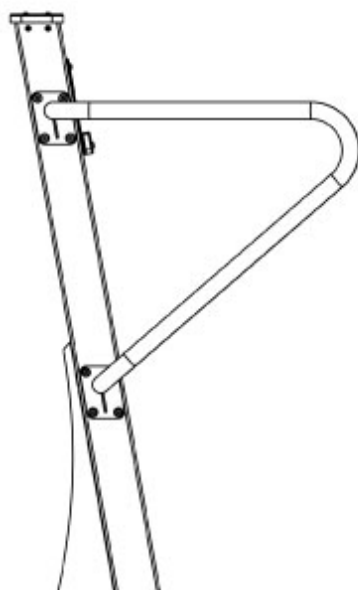

ATTREZZO FITNESS PER IL RINFORZO DEI MUSCOLI DELLE BRACCIA-MF117



P.M. MODIFICHE s.r.l.  
Via Amicizia 15 - 36027 Rosà (VI) - Italy  
CF / P.iva 02326230246

[myfun@pmmodifiche.it](mailto:myfun@pmmodifiche.it)  
[www.myfungiochi.it](http://www.myfungiochi.it)  
Tel +39 0424 219292

-  codice
-  altezza di caduta
-  area sicurezza
-  misure
-  pavimentazione

